



Estufas de Pellet

Salamandras de Pellet
Pellet Stove





Nuestra empresa

En FERLUX, llevamos más de 25 años dedicados a la fabricación y comercialización de chimeneas y barbacoas. Con sus dos plantas de producción situadas en la provincia de Málaga, FERLUX se ha posicionado como uno de los líderes en este sector.

En la actualidad y preocupados por nuestro medio ambiente y espíritu emprendedor FERLUX crea una nueva división de estufas de biomasa, con tecnología y fabricación 100% española.

En su departamento de I+D sigue innovando cada día para conseguir los mejores rendimientos y calidades en toda su gama de productos, aplicando para ello tecnología y personal 100% español.

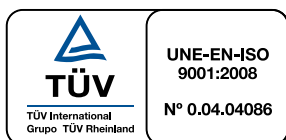



A Nossa Empresa

Na Ferlux, levamos mais de 25 anos dedicados ao fabrico e comercialização de recuperadores e churrasqueiras. Com duas fábricas situadas na província de Málaga, Ferlux posicionou-se como um dos líderes do sector.

Actualmente, preocupados com o meio ambiente, e com espírito empreendedor, Ferlux criou um novo departamento de salamandras de biomassa, com tecnologia e fabrico 100% Nacional.

O departamento de I+D, pesquisa e inova continuamente, de forma a alcançar o melhor rendimento e qualidade em toda a sua gama de produtos, aplicando tecnologia e pessoal 100% Nacional

Our Company

At FERLUX, we have been dedicated to the manufacture and marketing of fireplaces and barbecues for over 25 years. With our two production plants located in the province of Málaga, FERLUX has established itself as one of the leading companies in this sector.

Now, due to environmental concerns and thanks to our entrepreneurial spirit, FERLUX has created a new biomass stove division, using 100% Spanish technology and manufacture.

In our R & D department, this innovation continues every day, allowing us to achieve the best performance and quality throughout our product range due to the employment of 100% Spanish personnel and technology.



Biomasa y Pellet

¿Qué es el pellet y la biomasa?

Según el IDEA, **Instituto para la Diversificación y Ahorro de la Energía**, la biomasa es el conjunto de la materia orgánica, de origen vegetal o animal y los materiales que proceden de su transformación natural o artificial.

Incluye específicamente los residuos procedentes de las actividades agrícolas, ganaderas y forestales, así como los subproductos de las industrias agroalimentarias y de transformación de la madera.

El pellet es un combustible de madera seca y prensado en pequeños cilindros, sin aditivos, generado por la recuperación o utilización de subproductos derivados de la madera. La alta densidad energética y la facilidad de movimiento, hacen del pellet el combustible vegetal más indicado para sistemas de calefacción automáticos de todos los tamaños. Por sus características, el pellet se presenta en el mercado como una alternativa energética limpia frente al gas y al gasóleo, con un coste menor y respetuoso con el medio ambiente. Una gran ventaja del pellet es que no está afectado por las continuas fluctuaciones que sufren los combustibles fósiles, sujetos a cambios constantes por orígenes políticos y/o sociales.

Una estufa de pellet FERLUX es una segura forma de inversión, inteligente y respetuosa con el medio ambiente, ya que lo que en un inicio puede parecer un gasto, en un corto plazo de tiempo es un ahorro considerable.





Biomassa e Pellet

O que é o Pellet e a Biomassa?

Segundo o IDEA (Instituto para la diversificación y Ahorro de Energía) a biomassa é o conjunto da matéria orgânica, de origem vegetal ou animal e também os materiais que procedem da sua transformação natural ou artificial.

Inclui especificamente os resíduos procedentes das actividades agrícolas, pecuárias e florestais, bem como os subprodutos das indústrias agro-alimentares e da transformação da madeira.

O pellet é um combustível produzido com madeira seca e prensada em pequenos cilindros, sem aditivos, produzidos através da recuperação ou utilização de subprodutos derivados da madeira. A alta densidade energética e a facilidade de manuseamento, fazem do pellet o combustível vegetal mais indicado para os sistemas de aquecimento de todas as potências.

Devido às suas características, o pellet apresenta-se no mercado como uma alternativa energética limpa em relação ao gás e ao gasóleo, com um custo menor e amigo do meio ambiente. Uma grande vantagem do pellet é que não é afectado pelas contínuas flutuações que sofrem os combustíveis fósseis, que são sujeitos a mudanças constantes devido a problemas políticos e sociais.

Uma salamandra a pellet Ferlux é uma forma segura de investimento, inteligente e amiga do ambiente, e embora no início possa parecer um gasto, em pouco tempo traduz-se numa poupança considerável.

Biomass and Pellet

What are pellets and biomass?

According to the IDEA, Institute for the Diversification and Saving of Energy, biomass is the 'Ensemble of organic matter of vegetable or animal origin, or resulting from the natural or artificial transformation of vegetable or animal matter, which can be used (directly or indirectly) as a source of energy'.

It specifically includes waste from agricultural, livestock and forestry activities as well as by-products of the food and wood processing industries.

The pellets are a dry wood fuel pressed into small cylinders, without additives, generated by the use or recovery of by-products derived from wood. Their high energy density and ease of movement make them the most suitable fuel type for automated heating systems of all sizes. Due to their characteristics, the pellets are presented to the market as a clean alternative energy product in comparison to gas and diesel, with lower costs and more consideration for the environment.

One of the great advantages of the pellets, is they are not affected by the continuous fluctuations suffered by fossil fuels, which can be subject to constant change of political or social origin.

A FERLUX pellet stove is a safe and intelligent investment, respectful of the environment, which may at first seem expensive, but within a short period of time presents a considerable saving.

aire





aire

air/air

Las estufas de Aire FERLUX, están diseñadas para ofrecerle y cubrir sus necesidades, tanto térmicas como estéticas, con su silenciosa turbina y su innovador diseño, la estufa de aire FERLUX aprovecha el calor producido y lo impulsa a la estancia proporcionando una agradable sensación.

As salamandras de Ar Ferlux, são desenhadas para oferecer e suprir as suas necessidades, tanto térmicas como estéticas. Com a sua turbina silenciosa e seu desenho inovador, a salamandra de Ar Ferlux aproveita o calor produzido e o impulsiona à habitação, proporcionando uma sensação agradável.

FERLUX air stoves are designed to provide and meet both your heating and aesthetic needs with their silent turbine and innovative design, FERLUX air stoves use the heat produced to deliver hot air into the room, providing a pleasant ambience.

Flora 6,3 Kw 7,8 Kw

estufas de pellet



Negro
Negro
Black

Blanco
Branco
White

Burdeos
Bordeaux
Bordeaux

Kw 6,3 Kw 7,8 Kw	mm 420x516x900	Kg 17 Kg	Kg 90 Kg
Kw Min-Max 3,6 - 6,3 Kw 4 - 7,8 Kw	Min-Max 80 - 85 % 83 - 83 %	Min-Max 11 - 19 h 9 - 19 h	Ø 80 mm
40	m³ 150 m³ 195 m³	SI	Kg/h Min-Max 0,9 - 1,6 0,9 - 1,9

ESQUEMA DE MEDIDAS

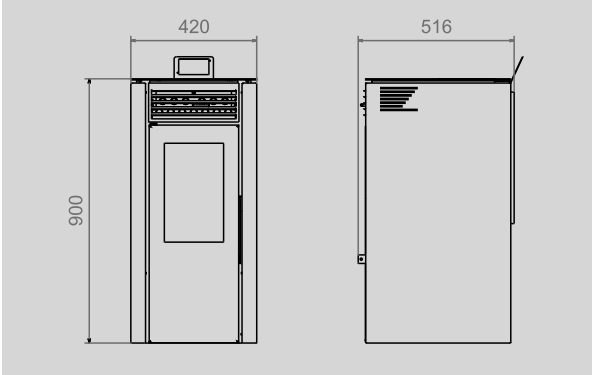



Negro
Negro
Black

Burdeos
Bordeaux
Bordeaux

Kw 6,3 Kw 7,8 Kw	mm 463x516x900	Kg 17 Kg	Kg 90 Kg
Kw Min-Max 3,6 - 6,3 Kw 4 - 7,8 Kw	Min-Max 80 - 85 % 83 - 83 %	Min-Max 11 - 19 h 9 - 19 h	80 mm
40	m³ 150 m ³ 195 m ³	SI	Kg/h Min-Max 0,9 - 1,6 0,9 - 1,9

ESQUEMA DE MEDIDAS

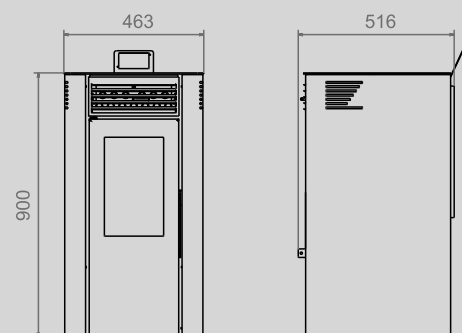



Blanco
Branco
White

Burdeos
Bordeaux
Bordeaux



6,3 Kw
7,8 Kw



420x516x915



17 Kg



90 Kg



3,6 - 6,3 Kw
4 - 7,8 Kw



80 - 85 %
83 - 83 %



11 - 19 h
9 - 19 h



80 mm



40



150 m³
195 m³



SI



0,9 - 1,6
0,9 - 1,9

ESQUEMA DE MEDIDAS

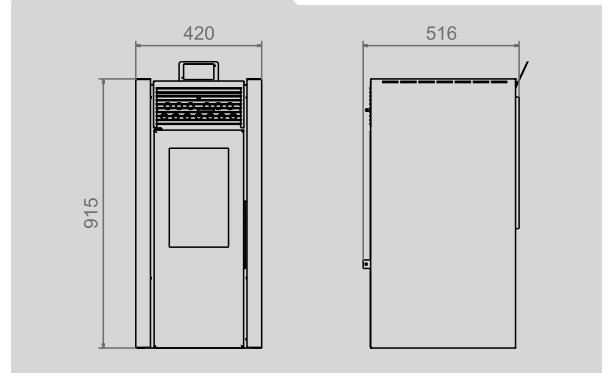



Burdeos
Bordeaux
Bordeaux

Blanco
Branco
White

Kw 6,3 Kw 7,8 Kw	mm 420x516x915	Kg 17 Kg	Kg 90 Kg
Kw Min-Max 3,6 - 6,3 Kw 4 - 7,8 Kw	Min-Max 80 - 85 % 83 - 83 %	Min-Max 11 - 19 h 9 - 19 h	∅ 80 mm
40	m³ 150 m ³ 195 m ³	SI	Kg/h Min-Max 0,9 - 1,6 0,9 - 1,9

ESQUEMA DE MEDIDAS

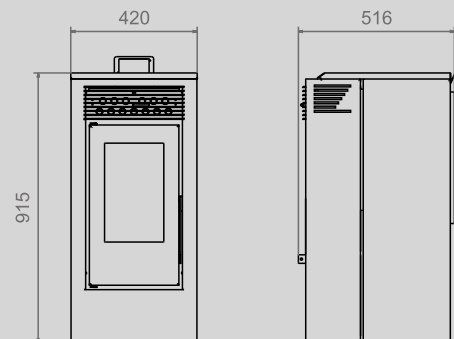



Blanco
Branco
White

Burdeos
Bordeaux
Bordeaux

Kw 10 Kw	mm 471x516x975	Kg 20 Kg	Kg 100 Kg
Kw Min-Max 4,1 - 10 Kw	Min-Max 90 - 87 %	Min-Max 8 - 22 h	80 mm
40	m³ 245 m ³	SI	Kg/h Min-Max 0,9 - 2,2



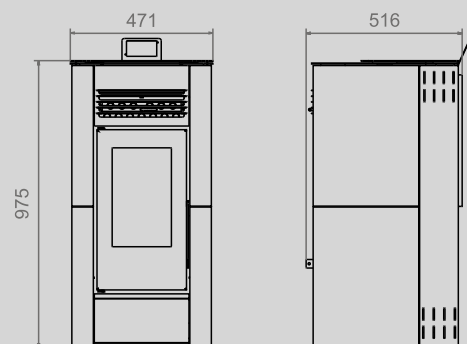









ESQUEMA DE MEDIDAS





Blanco
Branco
White

Burdeos
Bordeaux
Bordeaux

 10 Kw	 471x516x975	 20 Kg	 100 Kg
 4,1 - 10 Kw	 90 - 87 %	 8 - 22 h	 80 mm
 40	 245 m ³	 SI	 0,9 - 2,2













ESQUEMA DE MEDIDAS





Blanco
Branco
White

Burdeos
Bordeaux
Bordeaux

 10 Kw	 496x516x975	 20 Kg	 100 Kg
 4,1 - 10 Kw	 90 - 87 %	 8 - 22 h	 80 mm
 40	 245 m ³	 SI	 0,9 - 2,2

ESQUEMA DE MEDIDAS

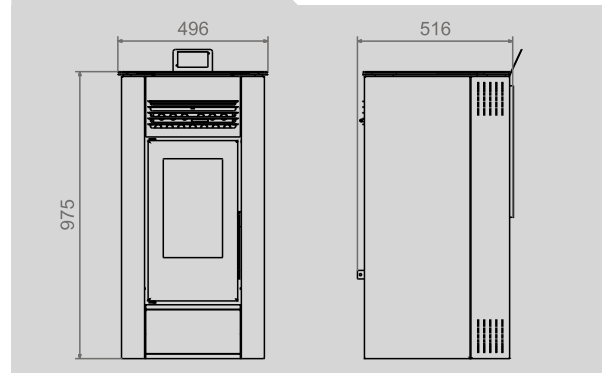

Nerea 10 Kw

estufas de pellet



Blanco
Branco
White

Burdeos
Bordeaux
Bordeaux

Kw 10 Kw	mm 496x516x975	Kg 20 Kg	Kg 100 Kg
Kw Min-Max 4,1 - 10 Kw	Min-Max 90 - 87 %	Min-Max 8 - 22 h	Ø 80 mm
40	m³ 245 m³	SI	Kg/h Min-Max 0,9 - 2,2

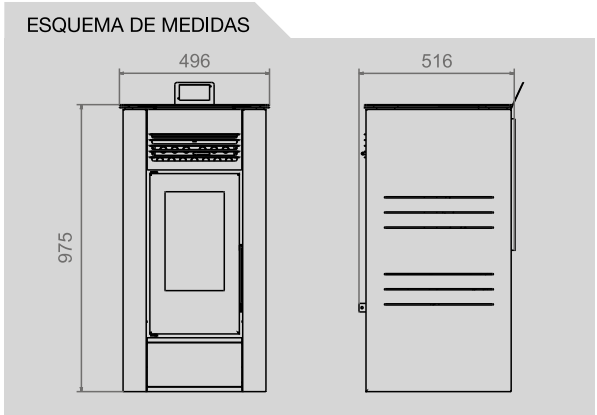



Blanco
Branco
White



Burdeos
Bordeaux
Bordeaux



12 Kw
15 Kw



556x563x1077



23 Kg



120 Kg



8,9 - 12 Kw
8,9 - 15,3 Kw



86 - 86 %



9 - 12 h
7 - 12 h



80 mm



60



325 m³
375 m³



SI



1,9 - 2,6
1,9 - 3,3

ESQUEMA DE MEDIDAS

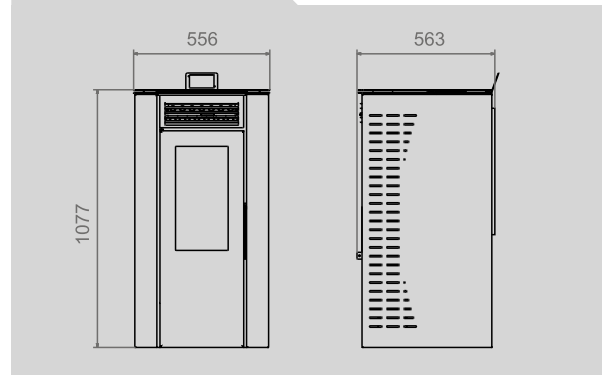

Estela 12 Kw 15 Kw

estufas de pellet

aire



Blanco
Branco
White

Burdeos
Bordeaux
Bordeaux

Kw 12 Kw 15 Kw	mm 558x563x1077	Kg 23 Kg	Kg 120 Kg
Kw Min-Max 8,9 - 12 Kw 8,9 - 15,3 Kw	Min-Max 86 - 86 %	Min-Max 9 - 12 h 7 - 12 h	Ø 80 mm
60	m³ 325 m ³ 375 m ³	SI	Kg/h Min-Max 1,9 - 2,6 1,9 - 3,3

ESQUEMA DE MEDIDAS





Blanco
Branco
White

Burdeos
Bordeaux
Bordeaux



12 Kw
15 Kw



536x563x1077



23 Kg



120 Kg



8,9 - 12 Kw
8,9 - 15,3 Kw



86 - 86 %



9 - 12 h
7 - 12 h



80 mm



60



325 m³
375 m³



SI



1,9 - 2,6
1,9 - 3,3

ESQUEMA DE MEDIDAS

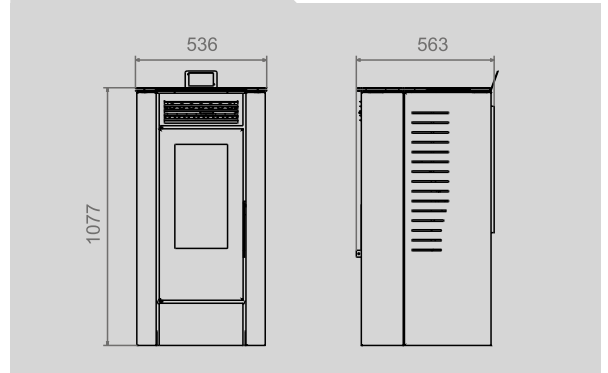



Blanco
Branco
White

Burdeos
Bordeaux
Bordeaux

Kw 12 Kw 15 Kw	mm 562x563x1077	Kg 23 Kg	Kg 120 Kg
Kw Min-Max 8,9 - 12 Kw 8,9 - 15,3 Kw	Min-Max 86 - 86 %	Min-Max 9 - 12 h 7 - 12 h	Ø 80 mm
60	m³ 325 m ³ 375 m ³	SI	Kg/h Min-Max 1,9 - 2,6 1,9 - 3,3

ESQUEMA DE MEDIDAS



acqua





agua

água / water

El innovador funcionamiento de las estufas de agua FERLUX, muy similar a una caldera, permite que todo el calor que nos proporciona el fuego, pase a nuestro circuito de agua, pudiendo así aprovecharlo, calentando radiadores, intercambiadores de calor, etc...













O funcionamento inovador da salamandra a água Ferlux, muito parecido a uma caldeira, permite que todo o calor que é proporcionado pelo fogo, seja transmitido ao circuito de água, sendo aproveitado para aquecer radiadores e termoventiladores.

The innovative FERLUX water heating stoves, very similar to a boiler, allow all the heat generated by the fire to be directed through the water circuit, thereby giving the advantage of being able to supply radiators or heat exchangers.



Blanco
Branco
White

Burdeos
Bordeaux
Bordeaux

 Min-Max 6,8 - 14,9 Kw 6,8 - 17,7 Kw	 561x591x1216	 25 Kg	 150 Kg
 Min-Max 5,5 - 12 Kw 5,5 - 15,6 Kw	 Min-Max 93 - 90 % 93 - 89 %	 Min-Max 9 - 19 h 7 - 19 h	 80 mm
 60	 250 m³ 375 m³	 SI	 Min-Max 1,35 - 3,0 1,35 - 3,6

ESQUEMA DE MEDIDAS

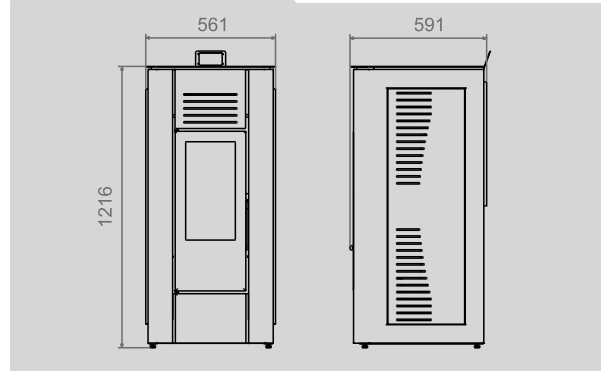

Delia 12 Kw 16 Kw

estufas de pellet

agua



Blanco
Branco
White

Burdeos
Bordeaux
Bordeaux

Kw
Min-Max

6,8 - 14,9 Kw
6,8 - 17,7 Kw

mm

561x591x1216

Kg

25 Kg

Kg

150 Kg

Kw
Min-Max

5,5 - 12 Kw
5,5 - 15,6 Kw

Min-Max

93 - 90 %
93 - 89 %

Min-Max

9 - 19 h
7 - 19 h

80 mm

60

m³

250 m³
375 m³

SI

Kg/h
Min-Max

1,35 - 3,0
1,35 - 3,6

ESQUEMA DE MEDIDAS

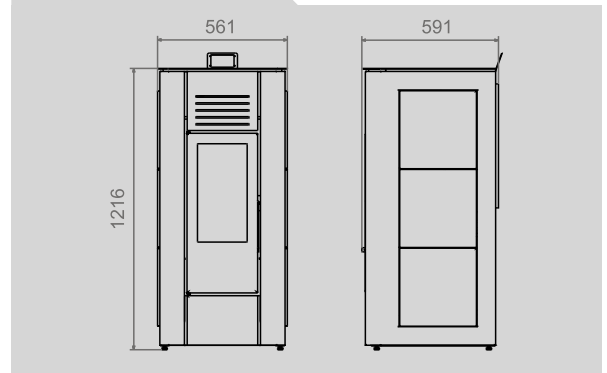



Bordeaux
Bordeaux
Bordeaux

Blanco
Blanco
White

Negro
Negro
Black



6,8 - 14,9 Kw
6,8 - 17,7 Kw



561x591x1216



25 Kg



150 Kg



5,5 - 12 Kw
5,5 - 15,6 Kw



93 - 90 %
93 - 89 %



9 - 19 h
7 - 19 h



80 mm



60



250 m³
375 m³



SI



1,35 - 3,0
1,35 - 3,6

ESQUEMA DE MEDIDAS

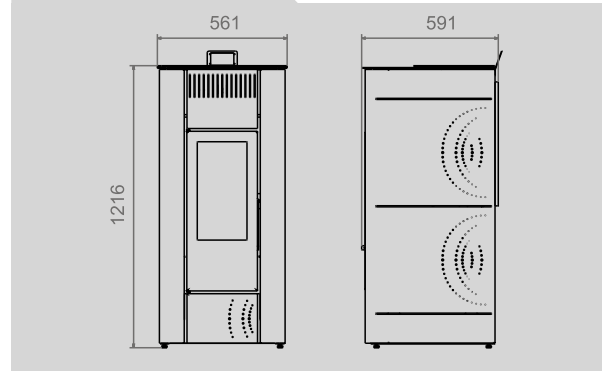

Velika

12 Kw
16 Kw

estufas de pellet

agua



Blanco
Branco
White

Burdeos
Bordeaux
Bordeaux

Kw
Min-Max

6,8 - 14,9 Kw
6,8 - 17,7 Kw

mm

561x591x1216

Kg

25 Kg

Kg

150 Kg

Kw
Min-Max

5,5 - 12 Kw
5,5 - 15,6 Kw

Min-Max

93 - 90 %
93 - 89 %

Min-Max

9 - 19 h
7 - 19 h

80 mm

60

m³

250 m³
375 m³

SI

Kg/h
Min-Max

1,35 - 3,0
1,35 - 3,6

ESQUEMA DE MEDIDAS

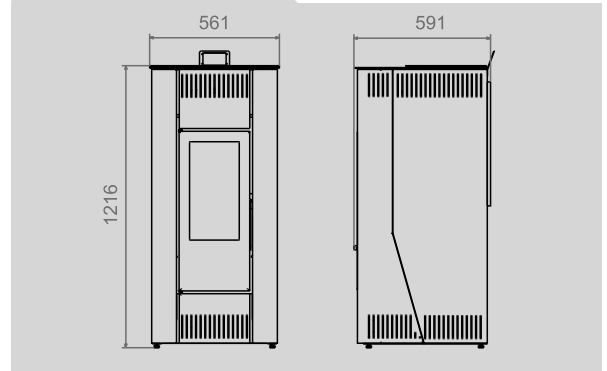



Blanco
Branco
White

Burdeos
Bordeaux
Bordeaux



14,2 - 27 Kw



561x591x1316



28 Kg



200 Kg



10,3 - 20,1 Kw



87 - 87 %



5 - 10 h



80 mm



60



690 m³



SI



3 - 5,7

ESQUEMA DE MEDIDAS

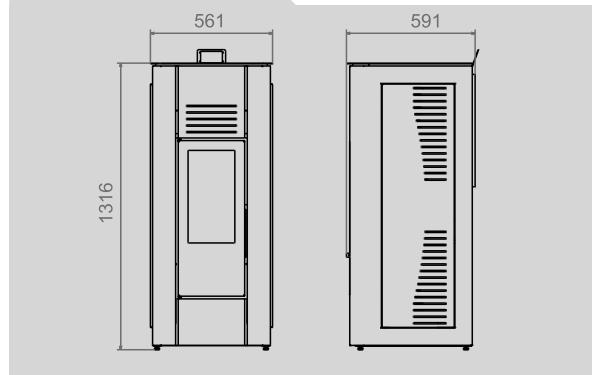

Delia 20 Kw













estufas de pellet

agua



Blanco
Branco
White

Burdeos
Bordeaux
Bordeaux

 Kw Min-Max	 mm	 Kg	 Kg
14,2 - 27 Kw	561x591x1316	28 Kg	200 Kg
 Kw Min-Max	 Min-Max	 Min-Max	 Ø
10,3 - 20,1 Kw	87 - 87 %	5 - 10 h	80 mm
 60	 m³	 SI	 Kg/h Min-Max
	690 m³		3 - 5,7

ESQUEMA DE MEDIDAS

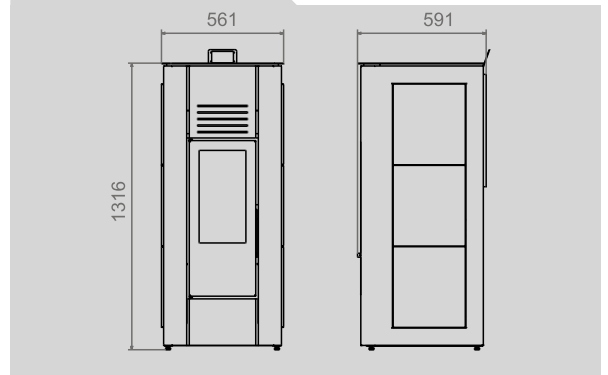

Selena 20 Kw

estufas de pellet

agua



Negro
Negro
Black

Blanco
Branco
White

Burdeos
Bordeaux
Bordeaux



14,2 - 27 Kw



561x591x1316



28 Kg



200 Kg



10,3 - 20,1 Kw



87 - 87 %



5 - 10 h



80 mm



60



690 m³



SI



3 - 5,7

ESQUEMA DE MEDIDAS

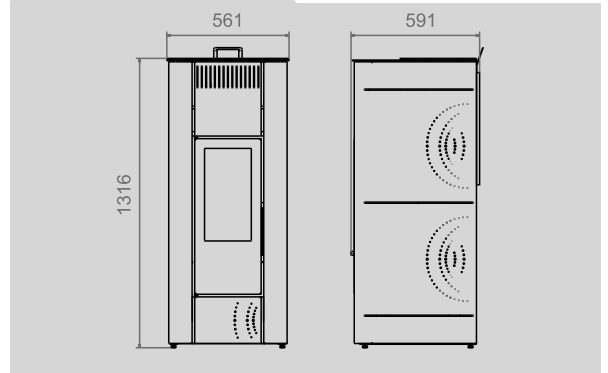



Blanco
Branco
White

Burdeos
Bordeaux
Bordeaux



14,2 - 27 Kw



561x591x1316



28 Kg



200 Kg



10,3 - 20,1 Kw



87 - 87 %



5 - 10 h



80 mm



60



690 m³



SI



3 - 5,7

ESQUEMA DE MEDIDAS

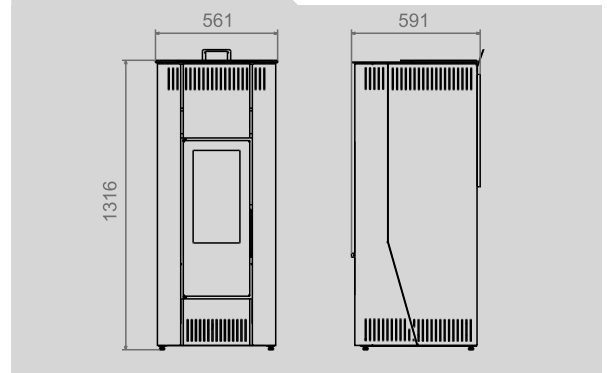

Características Técnicas

Características Técnicas / Technical Specifications

		Potencia Power (Kw)	Consumo Min - Max Consumption Min - Max (Kg/h)	Dimensiones Sizes (mm)	Depósito Pellet Tank	Peso Weight (Kg)	Potencia Min - Max Power Min-Max (Kw)	
aire / air / air	6,3 Kw	FLORA	6,3	0,9 - 1,6	420x516x900	17	90	3,6 - 6,3
		EVA	6,3	0,9 - 1,6	420x516x915	17	90	3,6 - 6,3
		YOLI	6,3	0,9 - 1,6	463x516x900	17	90	3,6 - 6,3
		SHARA	6,3	0,9 - 1,6	420x516x915	17	90	3,6 - 6,3
	7,8 Kw	FLORA	7,8	0,9 - 1,9	420x516x900	17	90	4 - 7,8
		EVA	7,8	0,9 - 1,9	420x516x915	17	90	4 - 7,8
		YOLI	7,8	0,9 - 1,9	463x516x900	17	90	4 - 7,8
		SHARA	7,8	0,9 - 1,9	420x516x915	17	90	4 - 7,8
	10 Kw	FANNY	10	0,9 - 2,2	471x516x975	20	100	4,1 - 10
		GALA	10	0,9 - 2,2	471x516x975	20	100	4,1 - 10
		NATALIA	10	0,9 - 2,2	496x516x975	20	100	4,1 - 10
		NEREA	10	0,9 - 2,2	496x516x975	20	100	4,1 - 10
	12 Kw	NELY	12	1,9 - 2,6	556x563x1077	23	120	8,9 - 12
		ESTELA	12	1,9 - 2,6	558x563x1077	23	120	8,9 - 12
		VERA	12	1,9 - 2,6	536x563x1077	23	120	8,9 - 12
		SANDRA	12	1,9 - 2,6	562x563x1077	23	120	8,9 - 12
15 Kw	NELY	15	1,9 - 3,3	556x563x1077	23	120	8,9 - 15,3	
	ESTELA	15	1,9 - 3,3	558x563x1077	23	120	8,9 - 15,3	
	VERA	15	1,9 - 3,3	536x563x1077	23	120	8,9 - 15,3	
	SANDRA	15	1,9 - 3,3	562x563x1077	23	120	8,9 - 15,3	

		Potencia Total Min - Max Total Power Min - Max (Kw)	Consumo Min - Max Consumption Min - Max (Kg/h)	Dimensiones Sizes (mm)	Depósito Pellet Tank	Peso Weight (Kg)	Potencia Agua Min - Max Total power water Min - Max (Kw)	
agua / agua / water	12 Kw	ALTEA	6,8 - 14,9	1,35 - 3,0	561x591x1216	25	150	5,5 - 12,0
		DELIA	6,8 - 14,9	1,35 - 3,0	561x591x1216	25	150	5,5 - 12,0
		SELENA	6,8 - 14,9	1,35 - 3,0	561x591x1216	25	150	5,5 - 12,0
		VELIKA	6,8 - 14,9	1,35 - 3,0	561x591x1216	25	150	5,5 - 12,0
	15,6 Kw	ALTEA	6,8 - 17,7	1,35 - 3,6	561x591x1216	25	150	5,5 - 15,6
		DELIA	6,8 - 17,7	1,35 - 3,6	561x591x1216	25	150	5,5 - 15,6
		SELENA	6,8 - 17,7	1,35 - 3,6	561x591x1216	25	150	5,5 - 15,6
		VELIKA	6,8 - 17,7	1,35 - 3,6	561x591x1216	25	150	5,5 - 15,6
	21,1 Kw	ALTEA	14,2 - 27	3 - 5,7	561x591x1316	28	200	10,3 - 20,1
		DELIA	14,2 - 27	3 - 5,7	561x591x1316	28	200	10,3 - 20,1
		SELENA	14,2 - 27	3 - 5,7	561x591x1316	28	200	10,3 - 20,1
		VELIKA	14,2 - 27	3 - 5,7	561x591x1316	28	200	10,3 - 20,1



Potencia total
Total power



Medidas
Measures



Tolva
Tank



Peso
Weight



Potencia al agua
Total power water



Rendimiento
Yield



Autonomía
Autonomy



Diámetro chimenea
Chimney diameter



Entrada de aire
Air inlet



Capacidad de calefacción
Heating capacity



Control remoto
Remote control



Consumo
Consumption

Rendimiento Min - Max Yield Min-Max (%)	Autonomía Min - Max Autonomy Min-Max (h)	Salida de humos Chimney diameter (mm)	Aspiración Air inlet	Volumen calefactable Heating capacity (m ³)	Mando a distancia Remote control	Programador horario Timer
80 - 85	11 - 19	80	40	150	Si	Si
80 - 85	11 - 19	80	40	150	Si	Si
80 - 85	11 - 19	80	40	150	Si	Si
80 - 85	11 - 19	80	40	150	Si	Si
83 - 83	9 - 19	80	40	195	Si	Si
83 - 83	9 - 19	80	40	195	Si	Si
83 - 83	9 - 19	80	40	195	Si	Si
83 - 83	9 - 19	80	40	195	Si	Si
90 - 87	8 - 22	80	40	245	Si	Si
90 - 87	8 - 22	80	40	245	Si	Si
90 - 87	8 - 22	80	40	245	Si	Si
90 - 87	8 - 22	80	40	245	Si	Si
86 - 86	9 - 12	80	60	325	Si	Si
86 - 86	9 - 12	80	60	325	Si	Si
86 - 86	9 - 12	80	60	325	Si	Si
86 - 86	9 - 12	80	60	325	Si	Si
86 - 86	7 - 12	80	60	375	Si	Si
86 - 86	7 - 12	80	60	375	Si	Si
86 - 86	7 - 12	80	60	375	Si	Si
86 - 86	7 - 12	80	60	375	Si	Si

Rendimiento Min - Max Yield Min - Max (%)	Autonomía Min - Max Autonomy Min - Max (h)	Salida de humos Chimney diameter (mm)	Aspiración Air inlet	Volumen calefactable Heating capacity (m ³)	Mando a distancia Remote control	Programador horario Timer
93 - 90	9 - 19	80	60	250	Si	Si
93 - 90	9 - 19	80	60	250	Si	Si
93 - 90	9 - 19	80	60	250	Si	Si
93 - 90	9 - 19	80	60	250	Si	Si
93 - 89	7 - 19	80	60	375	Si	Si
93 - 89	7 - 19	80	60	375	Si	Si
93 - 89	7 - 19	80	60	375	Si	Si
93 - 89	7 - 19	80	60	375	Si	Si
87 - 87	5 - 10	80	60	690	Si	Si
87 - 87	5 - 10	80	60	690	Si	Si
87 - 87	5 - 10	80	60	690	Si	Si
87 - 87	5 - 10	80	60	690	Si	Si



Potencia
Power



Medidas
Measures



Tolva
Tank



Peso
Weight



Potencia min-max
Power min - max



Rendimiento
Yield



Autonomía
Autonomy



Diámetro chimenea
Chimney diameter



Entrada de aire
Air inlet



Capacidad de calefacción
Heating capacity



Control remoto
Remote control



Consumo
Consumption



Chimeneas y Barbacoas FERLUX, S.A.
Parque Empresarial El Polear, Parc. 1
29313 Villanueva del Trabuco MÁLAGA (España)
Tel. +34 952 03 11 17 / Fax: +34 952 03 11 18

Ctra. Coín, 37
29140 Churriana MÁLAGA (España)
Tel. +34 952 62 22 27 / Fax: +34 952 62 16 82

Ferlux d.o.o. Beograd

Office: Mirijevski bulevar 29, 11.000 Beograd- Srbija
Store: Prvomajska 10, Staklara Pancevo- 26000 Pancevo- Beograd- Srbija.
Mobil: +381(0)60 3222455 / e-mail: ferluxbeograd@gmail.com
Prvomajska 10, Staklara Pancevo- 26000 Pancevo- Beograd- Serbia

**FERLUX se reserva el derecho a
modificar cualquier modelo de
este catálogo sin previo aviso.
Cotas a título orientativo.**



www.ferlux.es

